

Flexibility perfection: Oradoc improves creping performances

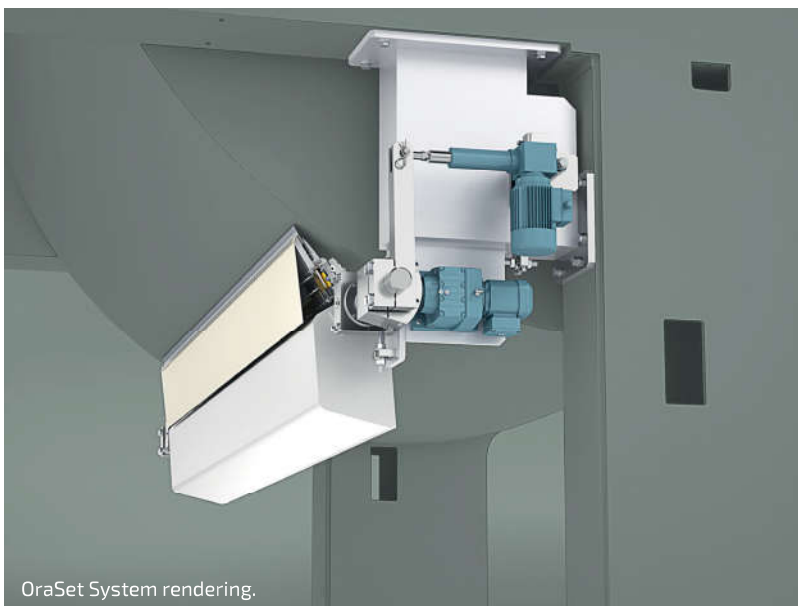

OraSet System rendering.

“ ORADOC can offer high performing solutions for cutting, cleaning and creping positions ”

ORADOC's expertise has grown together with the partnerships with its customers: starting from the analysis and the comparison of different requests, ORADOC has developed specific technical solutions tailored for different production and process needs, in order to provide its customers with tangible and measurable results. Always keeping an eye on the most advanced technologies, ORADOC has developed integrated systems able to meet the ever-changing needs of paper and tissue complex markets, thus guaranteeing high performance products. ORADOC can boast an in-depth knowledge of the productive process and this is the essential requirement to be able to offer its customer the best choice of materials and the best cleaning and creping solutions.

ORADOC was recently asked for intervention because a multinational company producing specialty papers was looking for a solution in order to be able to vary the creping angle of the center roll in the wet part more easily, as the pre-existing doctoring rigid system only allowed for manual adjustment when machine was not running: a complex, time-consuming and operator-dependent operation. To improve machine runnability and simplify the angle variation operation, ORADOC

For more than 30 years, ORADOC has been representing a benchmark in the designing, manufacturing, assembly and assistance for complex cleaning and creping solutions for the paper and tissue industry.

by: Oradoc S.r.l.



New Oradoc headquarters in Lucca.



► New Oradoc facilities and workshop.

“ ORADOC offers a wide range of integrated solutions for the tissue industry ”

▼ Example of OraSet System installation.

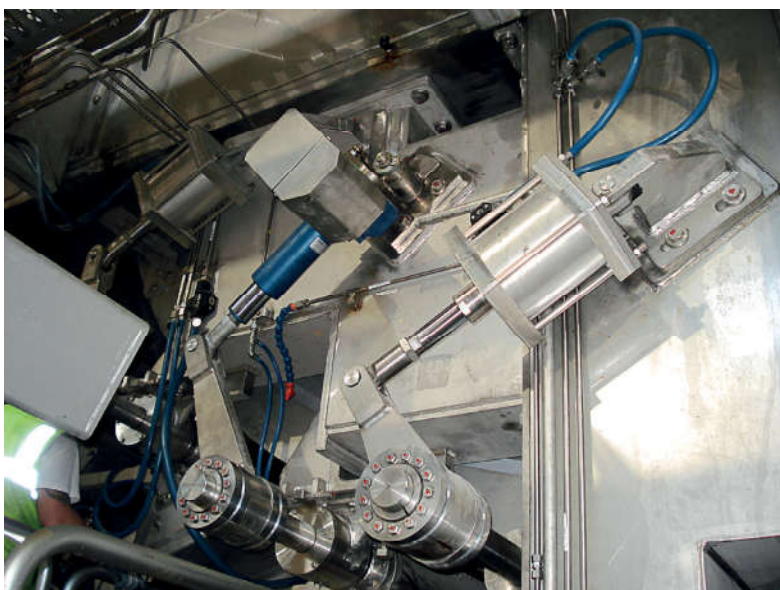

suggested the installation of the OraSet System, the evolution of the OraCrepe flexible creping doctor that allows changing the creping angle while the machine is running. Independent motors controlled by absolute encoders drive the unit and allow changing the blade angle with continuity, within a range of $\pm 5^\circ$ around the center value. This solution also allows lower linear working pressure and therefore extends the cylinder service life. This solution avoids unneeded downtime, a more precise angle measure thanks to incremental encoders and a completely automatic system, managed by an operator through a touch panel. After the installation of the OraSet System, performance guarantees were fully met over the given time and with great results. Once again, Oradoc proved to be a reliable partner able to meet the needs of its customers with tailor-made solutions. ●

ORADOC S.r.l.

Via dei Pasquinetti 183 55100 S.Pietro a Vico (LU) - Italy
phone: +39 0583 306454 - **fax:** +39 0322 956458
email: info@oradoc.net - **website:** www.oradoc.net
Oradoc is member of the WIVA Network